



BATTERY HYDRAULIC USER GUIDE

EFORCE

THIS GUIDE COVERS

11C-RIT3, 11C-SL3, 14C-SL3, 15C-SL3, 17C BRUTE, C195-SL3 NXT-GEN, C236-SL3 STANDARD, C236-SL3 NXTGEN, AII-9-EF, EFORCE MASTER SPECS 6-2020, RIT TIPS, S44-SL3, S49-SL3, S54-SL3, 21/36 RAM, 22/54 RAM, 31" RAM, 41" RAM, MASS TRANSIT CUT-TER, C365

CONTENTS

GENERAL INFO	4
ABOUT THE USER GUIDE	4
EXPLANATION OF SYMBOLS	5
LIMITATIONS OF LIABILITY	6
COPYRIGHT	6
WARRANTY CONDITIONS	7
CUSTOMER SERVICE	7
SAFETY	8
INTENDED USE	8-9
RESPONSIBILITY OF USER	10
OPERATING PERSONNEL	11
PERSONAL PROTECTIVE EQUIPMENT	12
SPECIFIC HAZARDS	13-14
HOW TO RESPOND	15
SIGNAGE	16
TECHNICAL DATA	17
CUTTER	17-21
ALL-9	21
CUTTER	23
RIT TIPS	24
CUTTER	25
SPREADER	26-28
OPERATING CONDITIONS	29
TYPE PLATE	29
DESIGN AND FUNCTION	30
OVERVIEW OF DEVICES	30-33
HYDRAULIC SUPPLY	34
ELECTRICAL SUPPLY	35-36
REPLACING BLADE INSERTS	37-39
CHANGING SPREADER TIPS	40
POSSIBLE APPLICATIONS	41
SAFETY INFORMATION	41
CUTTING	42
LIFTING / PRESSING	42

SPREADING	43
PULLING	44
CRUSHING	45
LIFTING	46
PEELING	46
BATTERY AND CHARGER	47
CHARGER TECHNICAL DATA	47
SPECIAL SAFETY INSTRUCTIONS	47-48
INTENDED USE	49
POWER LINE CONNECTION	49
LI-ION BATTERY	49
CHARGING	50
MAINTENANCE	51
CHARGING CYCLES	51
TRANSPORT AND STORAGE	52
SAFETY INFORMATION	52
TRANSPORT INSPECTION	52
DISPOSAL OF PACKAGING	53
STORAGE	53
INSTALLATION AND USE	54
SAFETY INFORMATION	54
CHECKING	54
SHUT-DOWN	55
SERVICE	56
SAFETY INFORMATION	56
CARE AND MAINTENANCE	56
MAINTENANCE SCHEDULE	57
TROUBLESHOOTING	58-59
DISPOSAL	60
NOTES	61

GENERAL INFORMATION

About the operating manual

This operating manual provides important information on using EFORCE devices. Proper compliance with all specified safety instructions and guidelines is a prerequisite for safe work

Furthermore, adhere to the local accident prevention guidelines and general safety regulations for the region in which the devices are used.

These operating instructions must be carefully read prior to starting any work! They are an inherent part of the product and must be kept in a place that is known and accessible to personnel at all times.

This documentation contains information for operating your equipment. However, you may also find information which may not directly apply to your specific equipment

All information, technical data, graphics and diagrams contained in these operating instructions are based on the latest data available at the time of the document's creation.

We recommend that, in addition to carefully reading through the operating manual, you be trained on handling the rescue equipment (possible applications, application tactics, etc.) by our qualified trainers

EXPLANATION OF SYMBOLS

Warnings

Warnings are marked by symbols in this operating manual. The individual instructions are introduced by signal words that express the severity of the hazard.

It is essential to comply with the instructions in order to prevent accidents, injuries and damage to property.



DANGER!

... indicates an imminently dangerous situation that can result in death or serious injury if not avoided.



WARNING!

... indicates a potentially dangerous situation that can result in death or serious injury if not avoided.



CAUTION!

... indicates a potentially dangerous situation that can result in minor or light injuries if not avoided.



ATTENTION!

... indicates a potentially dangerous situation that can result in material damage if not avoided.



NOTE!

... highlights useful tips and recommendations, as well as information for efficient, trouble-free operation.

LIMITATIONS OF LIABILITY

All information and instructions in this operating manual have been compiled in keeping with applicable standards and guidelines, the current state of technology, and our many years of knowledge and experience.

The manufacturer assumes no liability for damage due to:

- Failure to comply with the operating manual
- Unintended use
- Assignment of untrained personnel
- Unauthorized modification
- Technical changes
- Use of non-approved replacement parts
- Use of non-original replacement parts

The actual scope of delivery can vary from the explanations and graphic representations provided in this manual in the case of special versions, or due to technical changes.

COPYRIGHT

All texts, diagrams, drawings and images in this operating manual may be used without restriction and without any prior approval.



NOTE!

Further information, images and drawings can be found on our website www.genesisrescue.com

WARRANTY CONDITIONS

The warranty conditions can be found as a separate document in the sales documentation.

CUSTOMER SERVICE

Contact your local Genesis sales representative. If you are unsure you can contact Genesis Rescue Systems direct at:

Genesis Rescue Systems
2780 Culver Ave.
Kettering, Ohio
45429

Tel: 1.937.293.6240
Fax: 1.937.293.7049
www.genesisrescue.com



NOTE!

When contacting customer service please state your equipment's designation, type and production year. These details can be found on the equipment type plate.

SAFETY

This section of the operating manual provides a comprehensive overview of all important safety aspects for optimal protecting operating personnel and for safe, trouble-free operation.

Significant hazards may occur if the handling and safety instructions in this manual are not complied with.

INTENDED USE

The hydraulic battery-powered devices are designed and tested exclusively for the intended applications described here. All other activities are strictly forbidden.

BATTERY-POWERED DEVICES

- All battery-powered devices are designed as one-man devices and are therefore to be operated by only one person.
- The battery-powered cutting devices are used exclusively for cutting doors and roof beams, pillars and door sills, the ring and the spokes of the steering wheel.
- If possible, for cutting solid material, always position the material at the base of the cutter blades closest to the pivot point, as it is equipped with special edges for cutting round material.
- In industrial application, the devices can also be used to cut pipes, structural steels, profiles, sheets and cables
- The battery-powered spreading devices can be used for opening doors, lifting vehicles or other moveable loads, pushing away and moving vehicle parts and loads, and crushing pipes and tie bars.
- If possible, always use the tips of the spreader for crushing.

- The tips of the spreader can also be used as a peeling tool.
- The chain set is solely to be used for pulling.
- The combination devices can be used for both The applications cutting and spreading. The tips of the spreader can also be used as a peeling tool.

RAM, Telescopic Ram & Push Pull Ram

- The Ram is designed as a one-man device and is therefore to be operated by only one person.
- The Ram is exclusively for pushing up steering columns, vehicle roofs and other obstacles and for pushing away vehicle body parts.
- They can also be used for supporting and bracing loads.

WARNING!

Improper use can be dangerous!

Any improper or unintended use of the devices can be hazardous!

Therefore, make absolutely sure that:

- » The devices are used only for the applications stated above.



RESPONSIBILITY OF THE CUSTOMER

In addition to the health and safety instructions in this operating manual, one must adhere to the safety, accident prevention, and environmental protection guidelines for the region in which the equipment is used. Particularly applicable in this regard:

- The customer must be familiar with the applicable health and safety provisions and in a hazard analysis identify other hazards that may exist at the equipment's installation site due to the special working conditions.
- The customer must clearly regulate and specify responsibilities for installation, operation, maintenance and cleaning.
- The customer must ensure that all personnel who handle the equipment have fully read and understood the operating manual.
- In addition, at regular intervals, the operator must train personnel and inform them of the hazards of working with the equipment.

Moreover, the customer is responsible for ensuring that the equipment is always in technically faultless condition. Consequently, the following applies:

- After each use, and at least once a year, a visual inspection of the equipment must be carried out by a trained individual (according to GUV-G 9102 or country-specific guidelines)
- Every three years, or if you have doubts about the safety or reliability of the equipment, functional testing and stress testing must be carried out (according to GUV-G 9102 or country-specific guidelines)

OPERATING PERSONNEL

The following qualifications are cited in the operating instructions for the various activity areas:

- **Trained individual**
is informed through training offered by the customer about the tasks assigned to him and the possible dangers of improper conduct.
- **Specialist**
is someone who, due to specialized training, skills and experience, as well as knowledge of the applicable stipulations by the manufacturer, is capable of executing the tasks assigned to him or her and of independently recognizing possible hazards.



WARNING!

Inadequate training can result in injuries!

Improper handling of the equipment can lead to serious injury or material damage.

Therefore, make absolutely sure to:

- » allow particular tasks to be carried out only by the persons stated in the relevant chapter of this manual.
- » When in doubt, call in specialists immediately.



NOTE!

The equipment may not be used by personnel who have consumed alcohol, medication or drugs!

PERSONAL PROTECTIVE EQUIPMENT

Wearing personal protective equipment (PPE) is essential to minimize the risks to operating personnel when working with the hydraulic rescue devices.

It is essential to wear the following protective clothing for all work:



Protective work clothing

Tight-fitting work clothing with tight sleeves and no protruding part must be worn when working. It mostly serves to protect against entanglement by moving equipment parts.



Safety shoes

Steel-toed safety shoes must always be worn as protection against heavy falling parts and from slipping on slick surfaces.



Work gloves

Work gloves must be worn when working with the equipment to provide protection from sharp edges and shards of glass.



Helmet with face shield

A helmet with face shield must be worn for protection against flying or falling parts and shards of glass.



Protective goggles

Protective goggles must also be worn in addition to the face shield in order to protect the eyes from flying objects

The following must also be worn for certain work:



Ear protectors

In addition to the basic protective equipment, ear protectors must also be worn to protect your hearing.

SPECIFIC HAZARDS

The hazards arising from the risk analysis are listed in the following section.

Follow the safety instructions listed here and the warnings in the other sections of this manual to minimize potential health hazards and avoid dangerous situations.

ELECTRICITY



DANGER!

Danger of fatal electric shock!

There is an imminent life-threatening danger if live parts are touched. Damage to insulation or to specific components can pose a fatal hazard

Therefore:

- » If the insulation is damaged, immediately disconnect the power supply and arrange for repairs.
- » Allow only qualified electricians to work on the electrical equipment
- » For all work on the electrical equipment, it must be disconnected from the power source, and it must be checked that the device is powered off.
- » Prior to maintenance, cleaning and repair work, the power supply must be switched off and secured to prevent it from being switched back on again.
- » Do not bypass or disable fuses. When changing the fuses, ensure that they have the correct amperage.
- » Keep moisture away from live parts. This can lead to a short-circuit.

NOISE



WARNING!

Noise can damage hearing!

The noise occurring in the work area can cause severe hearing damage.

Therefore:

- »» You should also wear ear protectors when carrying out certain noise-producing tasks.
- »» Do not stay in the hazardous area longer than necessary.

HYDRAULIC POWER



WARNING!

Hydraulic power hazard!

Serious injury can result due to the released hydraulic forces and escaping hydraulic oil.

Therefore:

- »» Constantly monitor the device during the work procedure and set down if necessary.
- »» Inspect the hose lines and devices for damage after every use.
- »» Avoid skin contact with the hydraulic oil (wear protective gloves).
- »» Immediately remove the hydraulic oil from wounds and consult a doctor.

HOW TO RESPOND IN THE EVENT OF DANGER OR ACCIDENTS

Preventive measures

- Always be prepared for accidents
- Keep first aid equipment (first aid kit, blankets, etc.) at ha
- Familiarize personnel with accident alarms, first aid gea , and emergency equipment
- Keep entryways clear for emergency vehicles

In the event of an accident

- Shut down equipment immediately
- Initiate first aid measure
- Get people out of the danger zone
- Inform the responsible parties at the site of the incident
- Notify a doctor and/or the fire brigad
- Clear entryways for emergency vehicles

SIGNAGE

The equipment bears the following WARNING label.

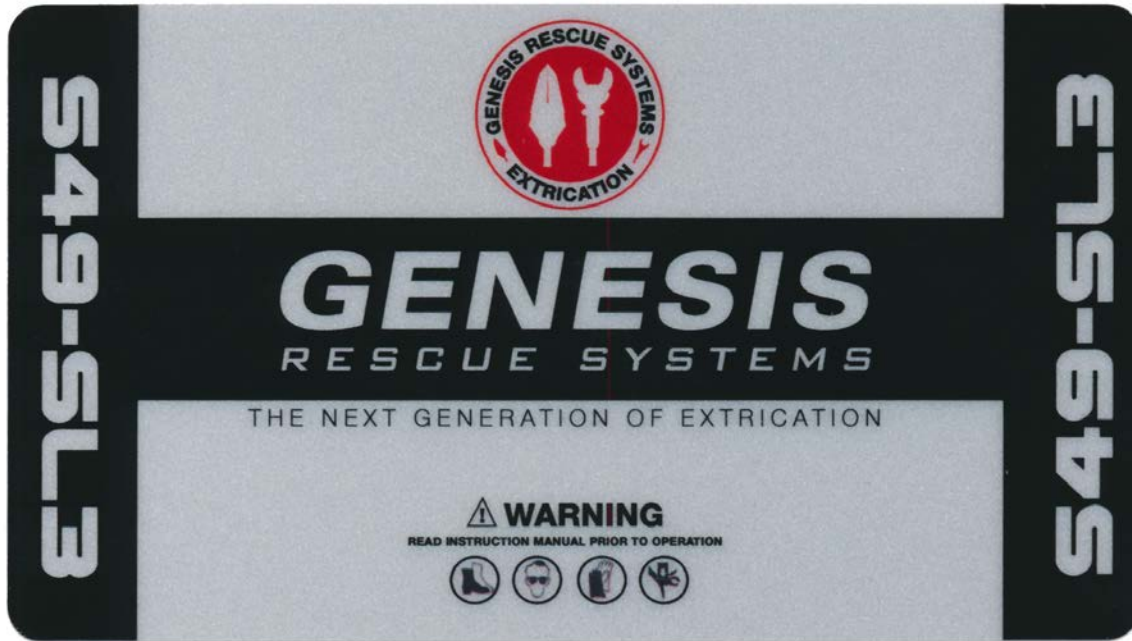

Comply with the operating manual

Do not use the marked equipment until you have read this operating manual.



WARNING!

Danger of injury due to illegible symbols!

Over time, stickers and symbols on the equipment can become soiled or otherwise illegible.

Therefore, make absolutely sure to:

- » Keep all safety, warning and operating information on the device easily legible.
- » Replace damaged signs and stickers immediately.

Tips are sold separately :
 RIT Tips - ART.109.685.9
 Brute Tip - ART.386.732.3
 Spot Weld Tip - ART.105.189.6



Shown with RIT tips

11C-RIT3 EFORCE

Part Number: ART.109.337.7

Length (mm/in)	824	32.4
Width (mm/in)	192	7.6
Height (mm/in)	241	9.5
Weight (kg/lbs)	14.9	32.8
Cutting Opening (mm/in)	285	11.2
Spreading Width (mm/in)	215	8.5
Pulling Distance (mm/in)	276	10.9
Ingress Protection Rating	IP54	IP54
Highest Spreading Force (kN/lbf)	30	6,750
Lowest Spreading Force (kN/lbf)	26	5,850
Highest Pulling Force (kN/lbf)	41	9,225
Lowest Pulling Force (kN/lbf)	35	7,875
NFPA Cut Rating	A6-B7-C6-D7-E7	A6-B7-C6-D7-E7
Nominal Pressure (bar/psi)	700	10,000

Images and Specifications are subject to change without notice



11C-SL3 EFORCE

Part Number: ART.109.351.5

Length (mm/in)	811	31.9
Width (mm/in)	192	7.6
Height (mm/in)	241	9.5
Weight (kg/lbs)	13.6	30.0
Cutting Opening (mm/in)	221	8.7
Spreading Width (mm/in)	270	10.6
Pulling Distance (mm/in)	352	13.9
Ingress Protection Rating	IP54	IP54
Highest Spreading Force (kN/lbf)	32	7,200
Lowest Spreading Force (kN/lbf)	24	5,400
Highest Pulling Force (kN/lbf)	45	10,125
Lowest Pulling Force (kN/lbf)	34	7,650
NFPA Cut Rating	A6-B7-C6-D7-E7	A6-B7-C6-D7-E7
Nominal Pressure (bar/psi)	700	10,000

Images and Specifications are subject to change without notice



14C-SL3 EFORCE

Part Number: ART.109.664.7

Length (mm/in)	927	36.5
Width (mm/in)	236	9.3
Height (mm/in)	241	9.5
Weight (kg/lbs)	18.8	41.4
Cutting Opening (mm/in)	285	11.2
Spreading Width (mm/in)	360	14.2
Pulling Distance (mm/in)	380	15.0
Ingress Protection Rating	IP54	IP54
Highest Spreading Force (kN/lbf)	40	9,000
Lowest Spreading Force (kN/lbf)	28	6,300
Highest Pulling Force (kN/lbf)	56	12,600
Lowest Pulling Force (kN/lbf)	39	8,775
NFPA Cut Rating	A7-B8-C6-D8-E8-F5	A7-B8-C6-D8-E8-F5
Nominal Pressure (bar/psi)	700	10,000

Images and Specifications are subject to change without notice



15C-SL3 EFORCE

Part Number: ART.109.664.9

Length (mm/in)	933	36.7
Width (mm/in)	236	9.3
Height (mm/in)	241	9.5
Weight (kg/lbs)	20	44.1
Cutting Opening (mm/in)	295	11.6
Spreading Width (mm/in)	370	14.6
Pulling Distance (mm/in)	360	14.2
Ingress Protection Rating	IP54	IP54
Highest Spreading Force (kN/lbf)	39	8,775
Lowest Spreading Force (kN/lbf)	28	6,300
Highest Pulling Force (kN/lbf)	54	12,150
Lowest Pulling Force (kN/lbf)	39	8,775
NFPA Cut Rating	A7-B8-C6-D8-E8-F5	A7-B8-C6-D8-E8-F5
Nominal Pressure (bar/psi)	700	10,000

Images and Specifications are subject to change without notice



17C-SL3 EFORCE

Part Number: ART.109.261.1

Length (mm/in)	969	38.1
Width (mm/in)	236	9.3
Height (mm/in)	241	9.5
Weight (kg/lbs)	21	46.3
Cutting Opening (mm/in)	342	13.5
Spreading Width (mm/in)	405	15.9
Pulling Distance (mm/in)	406	16.0
Ingress Protection Rating	IP54	IP54
Highest Spreading Force (kN/lbf)	40	9,000
Lowest Spreading Force (kN/lbf)	29	6,525
Highest Pulling Force (kN/lbf)	57	12,825
Lowest Pulling Force (kN/lbf)	36	8,100
NFPA Cut Rating	A7-B9-C7-D9-E9-F6	A7-B9-C7-D9-E9-F6
Nominal Pressure (bar/psi)	700	10,000

Images and Specifications are subject to change without notice



All-9 EFORCE
Part Number: ART.109.351.0

Length (mm/in)	1029	40.5
Width (mm/in)	298	11.7
Height (mm/in)	241	9.5
Weight (kg/lbs)	26.3	58.0
Cutting Opening (mm/in)	260	10.2
Ingress Protection Rating	IP54	IP54
NFPA Cut Rating	A9-B9-C9-D9-E9	A9-B9-C9-D9-E9
Nominal Pressure (bar/psi)	700	10,000

Images and Specifications are subject to change without notice



C195-SL3 NXTGEN

Part Number: ART.109.351.2

Length (mm/in)	898	35.4
Width (mm/in)	236	9.3
Height (mm/in)	241	9.5
Weight (kg/lbs)	20.6	45.4
Cutting Opening (mm/in)	185	7.3
Ingress Protection Rating	IP54	IP54
NFPA Cut Rating	A8-B9-C7-D9-E9-F4	A8-B9-C7-D9-E9-F4
Nominal Pressure (bar/psi)	700	10,000

Images and Specifications are subject to change without notice



Sold Separately

RIT Tips EFORCE

Part Number: ART.109.685.9

Length (mm/in)	124.5	4.9
Width (mm/in)	89	3.5
Height (mm/in)	50.8	2
Weight (kg/lbs)	0.9	2.15

Images and Specifications are subject to change without notice

TECHNICAL DATA

EFORCE



GENESIS

RESCUE SYSTEMS

Rev: 0



C236-SL3 NXTGEN

Part Number: ART.109.351.4

Length (mm/in)	994	39.1
Width (mm/in)	260	10.2
Height (mm/in)	241	9.5
Weight (kg/lbs)	23.5	51.8
Cutting Opening (mm/in)	210	8.3
Ingress Protection Rating	IP54	IP54
NFPA Cut Rating	A8-B9-C8-D9-E9-F4	A8-B9-C8-D9-E9-F4
Nominal Pressure (bar/psi)	700	10,000

Images and Specifications are subject to change without notice

TECHNICAL DATA

EFORCE



GENESIS

RESCUE SYSTEMS

Rev: 0



S54-SL3 EFORCE

Part Number: ART.109.173.5

Length (mm/in)	1015	40.0
Width (mm/in)	282	11.1
Height (mm/in)	241	9.5
Weight (kg/lbs)	20.9	46.1
Spreading Width (mm/in)	805	31.7
Pulling Distance (mm/in)	618	24.3
Ingress Protection Rating	IP54	IP54
Highest Spreading Force (kN/lbf)	68	15,300
Lowest Spreading Force (kN/lbf)	46	10,350
Highest Pulling Force (kN/lbf)	52	11,700
Lowest Pulling Force (kN/lbf)	26	5,850
Nominal Pressure (bar/psi)	700	10,000

Images and Specifications are subject to change without notice

Genesis Rescue Systems | 2780 Culver Ave. | Kettering, Ohio 45429 | info@genesishrescue.com | WWW.GENESISRESCUE.COM

TECHNICAL DATA

EFORCE



GENESIS

RESCUE SYSTEMS

Rev: 0



S49-SL3 EFORCE

Part Number: ART.109.173.6

Length (mm/in)	982	38.7
Width (mm/in)	282	11.1
Height (mm/in)	241	9.5
Weight (kg/lbs)	20.7	45.6
Spreading Width (mm/in)	735	28.9
Pulling Distance (mm/in)	558	22.0
Ingress Protection Rating	IP54	IP54
Highest Spreading Force (kN/lbf)	76	17,100
Lowest Spreading Force (kN/lbf)	51	11,475
Highest Pulling Force (kN/lbf)	54	12,150
Lowest Pulling Force (kN/lbf)	30	6,750
Nominal Pressure (bar/psi)	700	10,000

Images and Specifications are subject to change without notice

TECHNICAL DATA

EFORCE



GENESIS

RESCUE SYSTEMS

Rev: 0



S44-SL3 EFORCE

Part Number: ART.109.370.3

Length (mm/in)	877	34.5
Width (mm/in)	239	9.4
Height (mm/in)	241	9.5
Weight (kg/lbs)	17.3	38.1
Spreading Width (mm/in)	610	24.0
Pulling Distance (mm/in)	388	15.3
Ingress Protection Rating	IP54	IP54
Highest Spreading Force (kN/lbf)	52	11,700
Lowest Spreading Force (kN/lbf)	41	9,225
Highest Pulling Force (kN/lbf)	42	9,450
Lowest Pulling Force (kN/lbf)	21	4,725
Nominal Pressure (bar/psi)	700	10,000

Images and Specifications are subject to change without notice

Genesis Rescue Systems | 2780 Culver Ave. | Kettering, Ohio 45429 | info@genesishrescue.com | WWW.GENESISRESCUE.COM

OPERATING CONDITIONS

The permissible temperature range of the EFORCE devices is between -4°F and +176°F. Reliable operation cannot be guaranteed outside of this range.

TYPE PLATE

On all EFORCE devices, the type plate is located on the body. It shows the serial number, production date, nominal pressure and device designation.

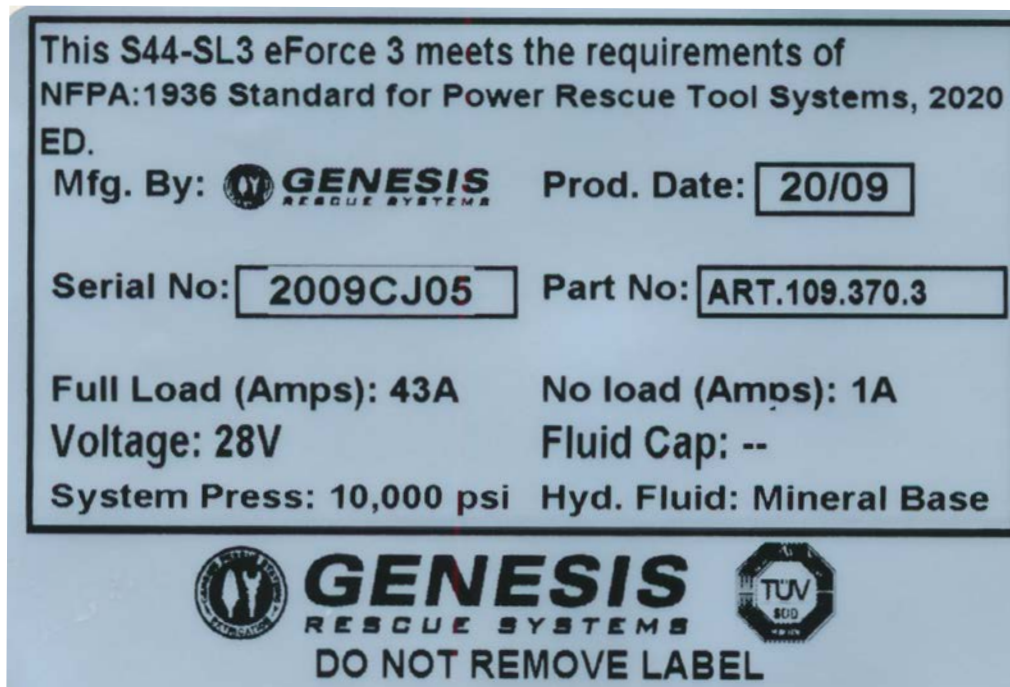

DESIGN AND FUNCTION

Overview of EFORCE devices

VARIO | COMBINATION TOOLS



Brief description of combination devices

Battery-powered combination devices are specially designed rescue equipment for cutting and spreading vehicle body parts. They are used to rescue trapped or enclosed accident victims. The combination device's uses include cutting door and roof beams, columns and sills, as well as opening doors, lifting vehicle parts and loads, and crushing pipes and beams.

Because the devices are equipped with internal electro-hydraulic drive, they are not linked to a power unit and can therefore be used in hard-to-reach locations.

The movement speed of the cutter blades (arms) is affected by moving the rocker lever on the control handle with greater or lesser force. The maximum force is achieved only when the rocker lever is on full activation.

DESIGN AND FUNCTION

Cutters



- 1 Blades (arms)
- 2 Protective cover
- 3 Hand grip
- 4 Cylinder body
- 5 Pumps / oil reservoirs
- 6 Control lever
- 7 Control handle
- 8 ON/OFF button
- 9 Battery

Brief description of cutter

Battery-powered cutters are specially designed rescue equipment for cutting vehicle body parts.

They are used to rescue trapped or enclosed accident victims. The cutter's uses include cutting door and roof beams, columns and sills.

Because the devices are equipped with internal electro-hydraulic drive, they are not linked to a power unit and can therefore be used in hard-to-reach locations.

The movement speed of the cutter blades is affected by moving the rocker lever on the control handle with greater or lesser force. The maximum cutting force is achieved only when the rocker lever is on full activation.

DESIGN AND FUNCTION

RAM



- 1 Battery
- 2 Pumps / oil reservoirs
- 3 ON/OFF button
- 4 Control handle
- 5 Control lever
- 6 Guide piece
- 7 Piston
- 8 Pushing head

Brief description of Rams

Battery-powered rams are specially designed rescue devices for pushing away parts of a vehicle body. They are used to rescue trapped or enclosed accident victims. The rescue cylinder is suitable for tasks such as pushing up steering columns, vehicle roofs and other obstacles.

Because the device is equipped with internal electro-hydraulic drive, it is not linked to a power unit and can therefore be used in hard-to-reach locations.

The ram is a supplement to the spreader and can be used, for example, if the spreading arm's spreading distance is no longer adequate.

The movement speed of the piston is affected by moving the rocker lever on the control handle with greater or lesser force. The maximum compressive force is achieved only when the rocker lever is on full activation.

DESIGN AND FUNCTION

Spreader



- 1 Spreader tips
- 2 Spreader arms
- 3 Hand grips
- 4 Cylinder body
- 5 Pumps / oil reservoirs
- 6 Control lever
- 7 Control handle
- 8 ON/OFF button
- 9 Battery

1

Brief description of spreader

Battery-powered spreaders are specially designed rescue devices for spreading, pressing and pulling. They are used to rescue trapped or enclosed accident victims. The spreaders are mainly suitable for opening doors, and for lifting vehicles and other movable loads.

Because the devices are equipped with internal electro-hydraulic drive, they are not linked to a power unit and can therefore be used in hard-to-reach locations. The movement speed of the spreading arms is affected by moving the rocker lever on the control handle with greater or lesser force. The maximum spreading force is achieved only when the rocker lever is on full activation.

HYDRAULIC SUPPLY

Drive

The battery devices are driven by a 28V DC motor with nominal power of approx. 700 watts. The drive motor runs only as long as the rocker lever is actuated.

Pump

The hydraulic pressure is generated by a high-pressure hydraulic pump (in the pumping unit). The pump is an swash plate axial piston pump with four pistons. The pressure operates directly on the working cylinder, making connection lines unnecessary.

Oil tank

The volume of oil for operation is taken from a piston accumulator. This means the entire hydraulic system is completely closed and void of air. The system pressure (accumulator pressure) is 7.25 PSI. Any possible volume expansion due to heat is balanced by the accumulator.

Hydraulic oil

All battery-powered devices should use a special hydraulic oil for rescue equipment in accordance with WN 4841751. Normally the oil does not have to be changed, but if this becomes necessary, it can be changed only by service engineers at GENESIS RESCUE SYSTEMS.

ELECTRICAL SUPPLY

Inserting the battery

Connect battery (1) to the rescue equipment (2). Slide the battery along the rails (3) provided for this purpose, until the battery clicks in. To release, press the push buttons on both sides of the battery (4). Then pull the battery up and out.



OPERATING EFORCE DEVICES

To start the battery-powered device, activate the ON/OFF switch (1). The switch glows green. The battery-powered device is operated by the rocker lever on the control handle. The movement speed can be precisely controlled by pressing with greater or lesser force.

The maximum cutting, spreading or compressive force is reached only if the rocker lever is pushed completely through.

Close cutter / Close spreader / Retract ram

The device's direction of movement is triggered by moving the rocker lever to the left.

Open cutter / Open spreader / Extend ram

The device's direction of movement is triggered by moving the rocker lever to the right.

Dead man's switch

If the rocker lever is released, it automatically goes back to the zero position. The device remains in the same place in every position (even under load).



EFORCE Control Unit



Left to close | Right to open

REPLACING BLADE INSERTS (C195, C236 NXTGEN EFORCE)

During blade replacement, the cutter is fixed in place. Any slipping should be avoided. Replacing the blade requires a soft-face hammer, the roll pins supplied, a punch and the blade inserts themselves. It makes sense to replace both blade inserts so that the cutting behavior is not impaired.



NOTE!

The blade inserts should not be reground, simply cleaning off any soil is recommended.

Procedure:



Fig. 1

The cutter is positioned with the type plate pointing upward and is fixed in place. A clamping device, as shown in the illustrations, is not obligatory. When the blade insert is being changed, the battery must be removed from the cutter and not under load. This means that the shear is not completely open or closed. The blade insert for the cutter blade with the smooth surface can now be replaced. The roll pins are knocked out and downward from the punch (see figure 1).



Fig. 2

After the roll pins have been knocked out of their position, the blade insert can be pulled out. The use of a forked screwdriver is recommended. If the blade insert cannot be loosened immediately, it can be gently levered out using a punch in the holes (see figure 2)

Fig. 3



Next, the cutter is rotated and the blade insert is placed in the cutter blade with no insert. When inserting, make sure that the blade insert does not twist. If the blade inserts cannot be inserted by hand, use the soft-face hammer (see figure 3)

Fig. 4



The roll pins are located using a punch and light blows of a hammer from above into the position holes provided for this purpose. Roll pins should be pushed into position until they are flush with the top surface of the blade (see figure 4)



Fig. 5

Next, the cutter is rotated and the blade insert is placed in the cutter blade with no insert. When inserting, make sure that the blade insert does not twist. If the blade inserts cannot be inserted by hand, use the soft-face hammer (see figure 3)



Fig. 6

The roll pins are located using a punch and light blows of a hammer from above into the position holes provided for this purpose. Roll pins should be pushed into position until they are flush with the top surface of the blade (see figure 4)

Changing the spreader tips (S44, S49, S54)

The spreader tips are secured in the spreader arms with collar studs. The studs are secured by a spring-loaded ball and must be pressed out for replacement. After the tips have been replaced, the collar studs can be pushed back through. Check that the studs are seated correctly (pressed completely in).

The holder for the chain set must be mounted in identical fashion. The chain lock must be installed with the latch facing upward.

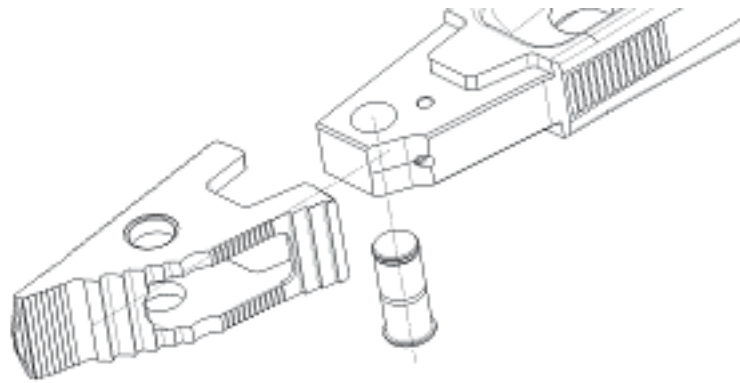

NOTE!

The chain lock is mounted in exactly the same way on the 11c EFORCE, 14c EFORCE, and 17c EFORCE. However, for this the spreader tips must first be removed. To do this, pulling device 2096617 must be attached to 11c EFORCE, pulling device 2835746 for 14c EFORCE and pulling device 2836033 for 17c EFORCE.

POSSIBLE APPLICATIONS

Safety information



WARNING!

Never reach between the blade arms!



WARNING!

During any work with battery-powered devices, voltage-carrying parts can break or fly off, thereby endangering people.

Uninvolved parties must therefore remain a safe distance away or stay in the danger zone only as long as necessary.

Cutting (Cutters, Combination devices)

The devices' cutting capabilities can only be used optimally if they are placed as near as possible to the blades' pivot point (Figure 1).

This means it may be necessary to readjust the device.

The device only achieves full cutting performance when the rocker lever is pressed all the way through. In addition, it can take several seconds for the unit to reach full operating pressure.

Fig. 1



CUTTING (CUTTERS, COMBINATION DEVICES)

To prevent the blades from being damaged, they must always be placed at right angles to the material to be cut.

Also, the tips of the blades must not be more than 5 mm apart during the cutting process. If this value is exceeded, the cutting process must be stopped and then started again.



CAUTION!

Do not sever any parts with loose ends, because this can result in personal injury due to parts flying off.



ATTENTION!

When cutting high-strength vehicle body parts, such as shock absorbers, hinges or steering columns, the shear blades (arms) may cause severe damage.

Lifting / pressing (Rams)

In its closed state, the rescue cylinder is positioned for lifting or pushing away vehicle body parts. Therefore, make sure that the cylinder is placed as centrally as possible and at a right angle to the load.

For better positioning, the pushing head can be turned on the piston rod.

Suspended parts must immediately be suitably braced and supported. It is forbidden to stay under suspended loads.



NOTE!

Before the rescue cylinder is used, the attachment point must be supported so that force develops in the desired direction.

SPREADING (SPREADERS, COMBINATION DEVICES)

The spreading function's uses include opening doors, lifting vehicles and other movable loads, pushing vehicle parts away, and squashing tubes and beams. For this, the vehicle must be stably stabilized and supported.

To prevent any sliding during spreading, the arms and tips are fluted inside and out. Whenever possible, the tips should be used only to enlarge a gap, because repositioning the spreader prevents slipping.

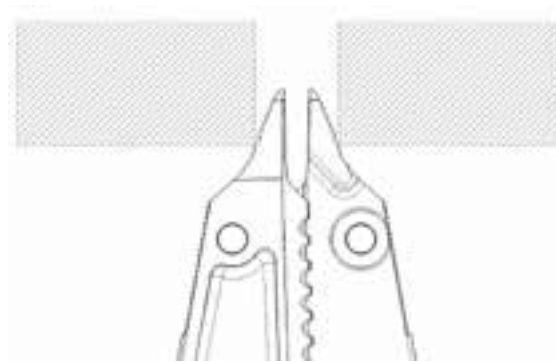
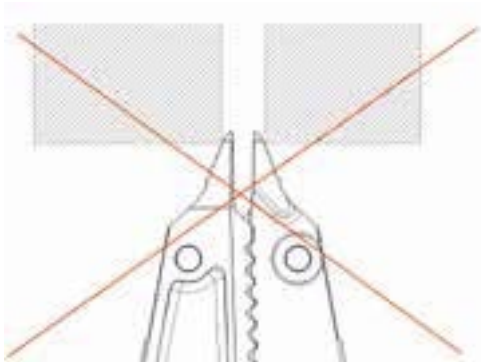
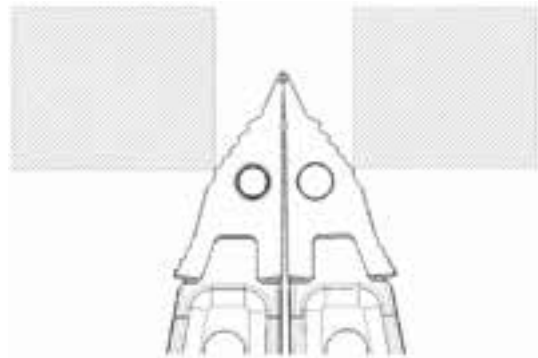
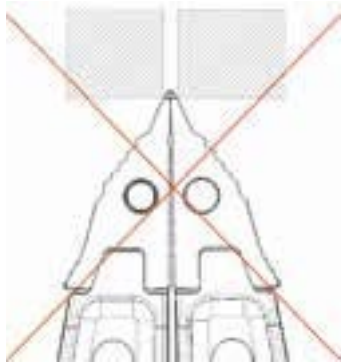

PULLING (SPREADERS, COMBINATION DEVICES)

After the chain set has been mounted on the spreader tips, the combination device can also be used for pulling.

For this, the chains must be tightly tensioned and must be tensed only in the pulling direction. To tension the chain, only one lock can be pressed in, so that the chain can be pulled through the holder.

If the range of movement is not sufficient, tension chains or other means must be used so that the spreader can be reopened and the chain re-tensioned.



ATTENTION!

Store the pulling chains with locks mounted about 4-8 in from the end. Check the chains prior to every use. Check that the weight does not stress the tip of the hook, but lies in the middle of the hook instead.

- » Do not make any repairs on your own.
- » Do not stress the chains beyond the permitted load carrying capacity.
- » Do not load with a jerking movement.
- » Do not galvanize or paint the chains.
- » Do not shorten the chain by knotting it.
- » Do not subject the chains to heat stress.
- » Use the chains and accessories only between -40°F and $+140^{\circ}\text{F}$.
- » During all maintenance work, observe the applicable safety regulations
- » Chains must only be used for pulling. Lifting loads is not permitted.

ATTENTION!

Chains must not be used if:



- » Deformations, cracks, signs of corrosion are present.
- » The wire diameter of the chain link has decreased by 10% of the nominal thickness.
- » An individual chain link has been permanently stretched.
- » An individual link has been enlarged by more than 2%.
- » The internal chain pitch over a measuring distance of 11 chain links has increased by more than 2%.

CRUSHING (SPREADERS, COMBINATION DEVICES)

Pipes and other hollow profiles are crushed by closing the spreader arms. With combination devices, however, crushing is only to be performed in the tip area.

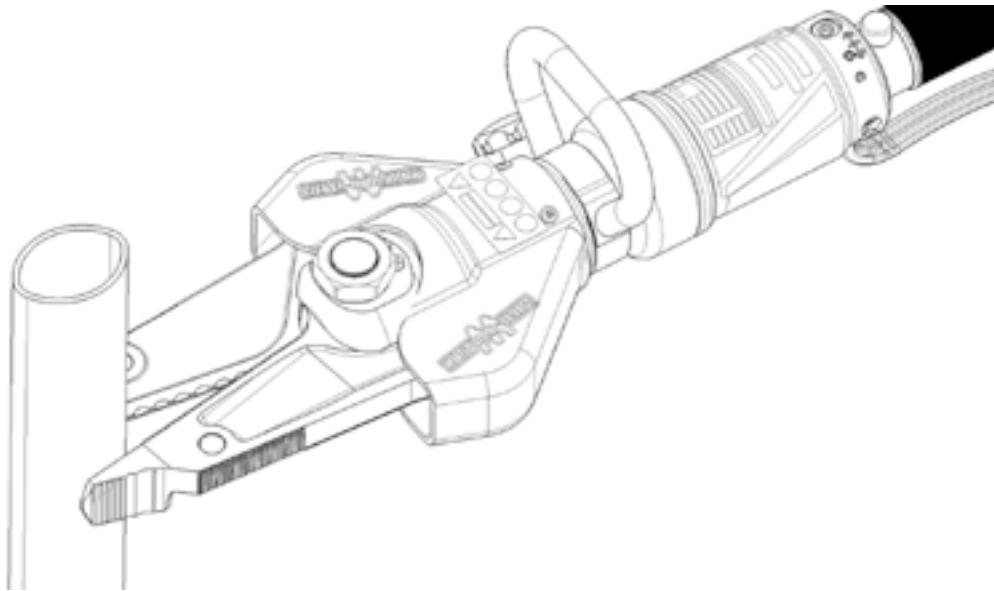

ATTENTION!

Material to be crushed can suddenly jump away.

Do not remain in the work area of the spreading and combination devices!

LIFTING (SPREADERS, COMBINATION DEVICES)

The combination device can also be used for lifting vehicles or other movable loads. Care must be taken to secure the load against slipping away and to position the spreader tips far enough apart under the load to prevent slipping.

The load being lifted must be constantly monitored (tipping, rolling away or changing position). Also, the lifted load must immediately be propped up and supported in a suitable way.

PEELING

To create entry openings after bus and train accidents, in silos, etc., both the spreader tips and the peeling tool can be used.

BATTERY AND CHARGER

Charger Technical Data

TECHNICAL DATA	CHARGER MCU
VOLTAGE RANGE	28V
CHARGING CURRENT, QUICK CHARGING	3.5A
CHARGING TIME	ca. 1h
WEIGHT (LBS/G)	1.5/700
INPUT VOLTAGE	PART NUMBER
220/240V AC 50/60 HZ EUROPE	ART.105.409.7
240V AC AUSTRALIA	ART.105.409.8
120V AC USA	ART.105.409.9



SPECIAL SAFETY INSTRUCTIONS

WARNING!

Do not throw used rechargeable batteries into a fire or into household waste. Your dealer can dispose of batteries in an environmentally sound manner.

The following batteries can be charged with the charger:

VOLTAGE	BATTERY TYPE	NOMINAL CAPACITY	NUMBER OF CELLS
28V	M28XC	≥ 5.0 Ah	2X7
28V	M28BX	≥ 3.0 Ah	2X7
28V	LI 28 V	≥ 3.0 Ah	2X7

BATTERY AND CHARGER



WARNING!

Important safety information concerning the battery and charger.

- » Do not use the charger to charge non-rechargeable batteries.
- » Do not store batteries together with metal objects (danger of short circuit).
- » Do not allow metal parts to enter the charger's battery insertion slot (danger of short circuit).
- » Do not open batteries and chargers, and store only in dry rooms. Protect from moisture.
- » The charger carries voltage from the power grid. Do not reach into the device with conductive objects.
- » Do not load a damaged battery — replace it immediately instead.
- » Before every use, check the device, connection cable, battery pack, extension cable and plug for damage and aging. Allow only qualified personnel to repair damaged parts.
- » This device is not designed for use by persons (including children) with limited physical, sensory or mental abilities, or lacking experience, and/or lacking expertise, unless they are supervised by a person responsible for their safety or have received instructions from this person on how to use the device. Children should be supervised to ensure that they do not play with the device.

BATTERY AND CHARGER

Intended use

This charger charges the 28V Li-ion battery of the M 28/V28 system delivered with the battery-powered device. This device must be used only as specified and intended

Power line connection

Only connect to single-phase AC current and only to the line voltage specified on the type plate. Connection to power sockets without an earthing contact is possible, because this is a protection class II design.

Li-ion battery

For safety reasons (air transport regulations), the batteries are delivered uncharged. Before first use, the battery must be completely charged.

LED charge status display



Figure 1

If the battery is not used for a prolonged period of time, the battery switches to standby mode. To use again, the battery must be reactivated (recharged).

The charge status can be called up by pressing the button on the battery(see Fig 1). To do this, the battery can remain in the battery-powered device, but it must be switched off at least 1 minute beforehand (otherwise the display will not be accurate). The number of glowing LEDs indicates the charge status.

The basic principle is: If the battery-powered device does not function after the battery is inserted, put the battery onto the charger for testing. The displays on the battery and charger give information about the battery charge status.

At low temperatures, the work can be still be carried out with lower performance. For best operational readiness, the batteries must be fully charged after use.

CHARGING PROCESS

After inserting the battery into the charger's insertion slot, the battery is charged automatically (red LED glows continuously).



If too warm or cold a battery is inserted into the charger (red LED flashes), the charging process starts automatically as soon as the battery has reached the correct charging temperature (0°C to 65°C). The maximum charging current flows if the temperature of the Li-ion battery is between 0°C and 65°C.



The charging time is between 1 min. and 60 min., depending on how much the battery has drained (at 3.0 Ah).



If the battery is fully charged, the LED on the charger switches from red to green. The battery does not need to be removed from the charger after charging. The battery can continue to stay in the charger. This cannot overload the battery, and it keeps the battery ready to use.

If both LEDs flash alternately, the battery is either not correctly placed or a malfunction of either the battery or charger has occurred. For safety reasons, remove the charger and battery from service immediately and have it checked by an authorized customer service center.



If the power adapter is overloaded, all LEDs flash 4 times. To be able to continue charging, unplug the power adapter and plug it back in.

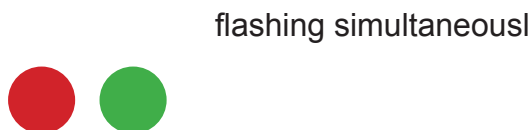

MAINTENANCE

If the power cable is damaged, it must be replaced by a customer service center.

Use only approved accessories and replacement parts. Parts whose replacement has not been described must be replaced by an authorized customer service center.

CHARGING CYCLES

TECHNICAL DATA	EXPLANATION
CHARGING CYCLES PARTIAL DISCHARGE PARTIAL DISCHARGE AND SUBSEQUENT RE-CHARGE DEEP CHARGE PROTECTION	~ 1000 NO EFFECT EACH RECHARGE COUNTS AS A FULL CHARGE IS PROVIDED

TRANSPORT, PACKAGING AND STORAGE

Safety information



CAUTION!

Incorrect transport can cause damage!
Improper transport can cause significant material damage

Therefore:

- » Proceed with caution when unloading the packages, and observe the symbols on the packaging.
- » Do not fully open and remove the package until it has reached its actual storage location.

Transport inspection

Upon receipt, the delivery should be checked immediately for completeness and damage during transport so that a quick remedy can be performed, if necessary.

If there is visible external damage, please proceed as follows:

- Do not accept the delivery, or only accept it with reservation.
- Note the extent of the transport damage on the transport documents or on the transport company's delivery note.
- File a complaint.



NOTE!

Report any defect as soon as it is detected.
Claims for damages can be directed to our customer service department.

DISPOSAL OF PACKAGING



All packaging materials and disassembled parts (transport protection) must be disposed of properly, in accordance with local regulations.

STORAGE

The equipment must be stored in a dry and dust-free environment, where possible. Avoid direct UV radiation to the hoses.



CAUTION!
The equipment must be stowed securely in the mountings provided in order to avoid damage during transit, etc.

INSTALLATION AND COMMISSIONING

Safety information



WARNING!

Danger of injury due to improper operation!
Improper operation can cause serious injury or material damage.

Therefore, make absolutely sure to:

- » All operating steps are executed in keeping with the information in this operating manual.
- » All covers and protective devices are installed and in proper working order prior to starting work.

Personal protective equipment

Wear the protective equipment for all work!



NOTE!

Special reference is made where it is necessary to wear additional protective equipment for certain work with or on the device.

CHECKING

Inspect the EFORCE device for damage. If the cutting device is not in pristine condition, it must not be used! In this case, immediately contact your supplier.

EFORCE combination devices, cutters and spreaders:

- Check the blades (for damage)
- Inspect the spreader tips (for damage)
- Check the control handle including the rocker lever (function)
- Check the handle (secure attachment)
- Check the protective cover (for damage)

EFORCE Rams:

- Check the piston rod (for damage)
- Check the control handle including the rocker lever (function)
- Check the plungers (for damage)
- Check the guide piece (for damage)

SHUT-DOWN (END OF WORK)

Cutters:

After work is over, the blade tips must be placed one above the other to prevent injury. The blades of the cutting device must not be completely closed, as otherwise tension will build up in the device.

Rams:

After work is over, the cylinder's piston rod must be completely retracted, so as to relieve the hydraulic load on the device.

Combination devices and spreaders:

After work is over, the spreading arms must remain slightly open, so as to relieve the hydraulic load on the device.

SERVICE

Safety information



WARNING!

Risk of injury due to improperly performed maintenance work!

Improper maintenance of the equipment can cause serious injury or material damage.

Therefore, make absolutely sure to:

- » Only let qualified personnel carry out maintenance work
- » Make sure the installation site is organized and clean! Loose components and tools lying around are sources of danger.
- » Wear protective gloves for all work!

CARE AND MAINTENANCE

PREVENTATIVE MAINTENANCE

Genesis recommends that all hydraulic rescue tools be serviced by a certified factory technician at a frequency of once every 12 months. Just like a vehicle this crucial maintenance ensures the tool functions at top performance and safety. Your sales representative can answer any question you may have.

We recommend only qualified personnel carry out maintenance.

GENESIS PREVENTATIVE MAINTENANCE PROGRAM

The following are recommended service intervals for Genesis tools.

Each Use

- Equipment should be wiped down to remove debris
- Clean cutter blades
- check cutter blades for damage
- Check Spreader Tips and arms for damage
- Check Combination Tips and arms for damage
- Lubricate blades, pins and toggles with WD40 or equivalent

Weekly Inspections and Maintenance

- Run each tool and build pressure
- Check handles and guards, tighten if necessary
- Torque centerbolt on cutters and combination tools to factory specification



ATTENTION!

Prior to all maintenance work, the equipment must be cleaned of any dirt so that it does not get into the hydraulic system.

The cleaning can be carried out using a conventional citrus cleaner or using WD 40.

MAINTENANCE SCHEDULE

A precise maintenance plan with testing intervals, regulations and results can be requested from your sales representative.



NOTE!

If there are any problems with the maintenance of the devices, contact your local sales representative.

TROUBLE SHOOTING

Combi devices and cutters:

Malfunction	Possible cause	Remedy
Device does not reach full performance	Rocker levers not completely pressed to the side	Press the rocker lever completely to the side
Combi device moves in opposite direction under load	Check if valve is defective	Have the device checked by an authorized service centre.
Blades are loose and gape apart during cutting	Blade not attached to the cutter head as specified	Have repaired by an authorized workshop
Blade opening below target value	Cutter head settings altered	Have repaired by an authorized workshop
Combi device's opening width below target value	Cutter head settings altered	Have repaired by an authorized workshop
Pressure build-up despite movement (open - closed) without load	Hex nut / central bolt too tight	Have repaired by an authorized workshop
Blade chipping	Blades damaged e.g. from cutting high-strength materials	Regrindable to about 2 mm, see repair manual, otherwise replace
Cracks in the blades	Blades damaged e.g. from cutting high-strength materials	Have the blades replaced by an authorized service centre
Rescue equipment does not function	Battery is dead	Place the battery on the charger. The displays on the battery and charger give information about the battery charge status.

RAM

Malfunction	Possible cause	Remedy
Device does not reach full performance	Rocker levers not completely pressed to the side	Press the rocker lever completely to the side
Cylinder moves in opposite direction under load	Check if valve is defective	Have the device checked by an authorized service centre
Rescue equipment does not function	Battery is dead	Place the battery on the charger The displays on the battery and charger give information about the battery charge status

SPREADER

Malfunction	Possible cause	Remedy
Device does not reach full performance	Rocker levers not completely pressed to the side	Press the rocker lever completely to the side
Spreader moves in opposite direction under load	Check valve defective	Have the device checked by an authorized service centre
Rescue equipment does not function	Battery is dead	Place the battery on the charger. The displays on the battery and charger give information about the battery charge status

DECOMMISSIONING/RECYCLING

After the end of the normal service life, the equipment must be professionally disposed of. Individual parts can, however, certainly be used again.

The hydraulic oil must be completely drained and collected. Make sure that the hydraulic oil is disposed of separately!

For disposal of all device components and packaging materials, the disposal conditions of the specific location apply.

Do not discard electric tools with household waste!



NOTE!

Please ask your supplier about disposing of the device.



GENESIS RESCUE SYSTEMS
2780 CULVER AVE.
KETTERING, OHIO 45329
TEL: 1.937.293.6240
WWW.GENESISRESCUE.COM